

RADIANCE MULTI-RATE LINE CARD

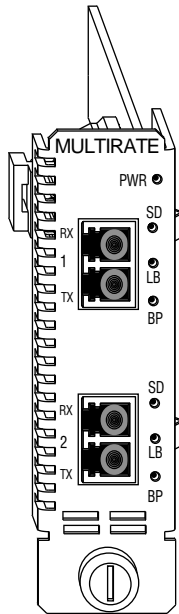

Installation & User Guide

Model: R380-SS

Radiance Multi-Rate Line Card

Line Card:

R380-SS _____ Multi-rate SFP to SFP

Small Form-Factor Pluggable (SFP) Multimode Optics:

O211-M5 _____ GigE SFP LC (multimode, 500 m)

O280-M2 _____ OC-3 SFP LC (multimode, 2 km) without digital diagnostics

O293-M5 _____ Multi-rate SFP LC (multimode, 50 Mbps to 700 Mbps, 500 m)

SFP Singlemode Optics:

O283-20 _____ Multi-rate SFP LC (singlemode, 10 Mbps to 155 Mbps, 20 km)

O293-20 _____ Multi-rate SFP LC (singlemode, 125 Mbps to 622 Mbps, 20 km)

O2A3-10 _____ Multi-rate SFP LC (singlemode, 155 Mbps to 2.67 Gbps, 10 km)

SFP Bi-Directional Wavelength Division Multiplexing (BWDM) Optics:

O311-10-31 _____ GigE SFP SC (BWDM, 1310 nm TX / 1490 nm RX, 10 km)

O311-10-49 _____ GigE SFP SC (BWDM, 1490 nm TX / 1310 nm RX, 10 km)

O383-20-31 _____ OC-3 SFP SC (BWDM, 1310 nm TX / 1550 nm RX, 20 km)

O383-20-55 _____ OC-3 SFP SC (BWDM, 1550 nm TX / 1310 nm RX, 20 km)

SFP Coarse Wavelength Division Multiplexing (CWDM) Optics:

O411-80-31 _____ SFP LC (CWDM, 1.062 Gbps to 1.25 Gbps, 1310 nm, 80 km)

O411-80-33 _____ SFP LC (CWDM, 1.062 Gbps to 1.25 Gbps, 1330 nm, 80 km)

O411-80-35 _____ SFP LC (CWDM, 1.062 Gbps to 1.25 Gbps, 1350 nm, 80 km)

O411-80-37 _____ SFP LC (CWDM, 1.062 Gbps to 1.25 Gbps, 1370 nm, 40 km)

O411-80-39 _____ SFP LC (CWDM, 1.062 Gbps to 1.25 Gbps, 1390 nm, 40 km)

O411-80-41 _____ SFP LC (CWDM, 1.062 Gbps to 1.25 Gbps, 1410 nm, 80 km)

O411-80-43 _____ SFP LC (CWDM, 1.062 Gbps to 1.25 Gbps, 1430 nm, 80 km)

O411-80-45 _____ SFP LC (CWDM, 1.062 Gbps to 1.25 Gbps, 1450 nm, 80 km)

O411-80-47 _____ SFP LC (CWDM, 622 Mbps to 1.25 Gbps, 1470 nm, 80 km)

O411-80-49 _____ SFP LC (CWDM, 622 Mbps to 1.25 Gbps, 1490 nm, 80 km)

O411-80-51 _____ SFP LC (CWDM, 622 Mbps to 1.25 Gbps, 1510 nm, 80 km)

O411-80-53 _____ SFP LC (CWDM, 622 Mbps to 1.25 Gbps, 1530 nm, 40 km)

O411-80-55 _____ SFP LC (CWDM, 622 Mbps to 1.25 Gbps, 1550 nm, 40 km)

O411-80-57 _____ SFP LC (CWDM, 622 Mbps to 1.25 Gbps, 1570 nm, 80 km)

O411-80-59 _____ SFP LC (CWDM, 622 Mbps to 1.25 Gbps, 1590 nm, 80 km)

O411-80-61 _____ SFP LC (CWDM, 622 Mbps to 1.25 Gbps, 1610 nm, 80 km)

O413-40-47 _____ Multi-rate SFP LC (CWDM, 45 Mbps to 2.7 Gbps, 1470 nm, 40 km)

O413-40-49 _____ Multi-rate SFP LC (CWDM, 45 Mbps to 2.7 Gbps, 1490 nm, 40 km)

O413-40-51 _____ Multi-rate SFP LC (CWDM, 45 Mbps to 2.7 Gbps, 1510 nm, 40 km)

O413-40-53 _____ Multi-rate SFP LC (CWDM, 45 Mbps to 2.7 Gbps, 1530 nm, 40 km)

O413-40-55 _____ Multi-rate SFP LC (CWDM, 45 Mbps to 2.7 Gbps, 1550 nm, 40 km)

O413-40-57 _____ Multi-rate SFP LC (CWDM, 45 Mbps to 2.7 Gbps, 1570 nm, 40 km)

O413-40-59 _____ Multi-rate SFP LC (CWDM, 45 Mbps to 2.7 Gbps, 1590 nm, 40 km)

O413-40-61 _____ Multi-rate SFP LC (CWDM, 45 Mbps to 2.7 Gbps, 1610 nm, 40 km)

O413-80-47 _____ Multi-rate SFP LC (CWDM, 45 Mbps to 2.7 Gbps, 1470 nm, 80 km)

O413-80-49 _____ Multi-rate SFP LC (CWDM, 45 Mbps to 2.7 Gbps, 1490 nm, 80 km)

O413-80-51 _____ Multi-rate SFP LC (CWDM, 45 Mbps to 2.7 Gbps, 1510 nm, 80 km)

O413-80-53 _____ Multi-rate SFP LC (CWDM, 45 Mbps to 2.7 Gbps, 1530 nm, 80 km)

O413-80-55 _____ Multi-rate SFP LC (CWDM, 45 Mbps to 2.7 Gbps, 1550 nm, 80 km)

O413-80-57 _____ Multi-rate SFP LC (CWDM, 45 Mbps to 2.7 Gbps, 1570 nm, 80 km)

O413-80-59 _____ Multi-rate SFP LC (CWDM, 45 Mbps to 2.7 Gbps, 1590 nm, 80 km)

O413-80-61 _____ Multi-rate SFP LC (CWDM, 45 Mbps to 2.7 Gbps, 1610 nm, 80 km)

Table of Contents

Radiance Multi-Rate Line Card Installation & User Guide

<i>Overview</i>	4
<i>Installation Guide</i>	7
Unpack the Line Card	7
Set the DIP Switches	7
Configuring the Data Rate	8
Loopback (LBCK) Switch	9
Link Loss Carry Forward (LLCF) Switch	9
Link Loss Return (LLR) Switch	9
Install the SFP Optics	10
Install the Line Card	11
Connect to the Network	11
<i>User Guide</i>	14
LED Operation	14
SFP Monitors	15
Loopback	16
Normal Operation	16
Local Port Loopback	16
Dual-Port Loopback	17
Link Loss Return	18
Link Loss Carry Forward	19
Topology Solutions	20
Coarse Wavelength Division Multiplexing (CWDM)	20
Changing the SFP Optics	22
Technical Specifications	23
Acronyms and Abbreviations	27
Product Safety, EMC and Compliance Statements	28
Warranty and Servicing	29

This publication is protected by the copyright laws of the United States and other countries, with all rights reserved. No part of this publication may be reproduced, stored in a retrieval system, translated, transcribed, or transmitted, in any form, or by any means manual, electric, electronic, electromagnetic, mechanical, chemical, optical or otherwise, without prior explicit written permission of Metrobility Optical Systems, Inc.

Metrobility, Metrobility Optical Systems and NetBeacon are registered trademarks; the Metrobility Optical Systems logo and WebBeacon are trademarks of Metrobility Optical Systems, Inc. Other trademarks appearing in this manual are the property of their owners.

The information contained in this document is assumed to be correct and current. The manufacturer is not responsible for errors or omissions and reserves the right to change specifications at any time without notice.

Overview

The Radiance multi-rate line card with dual small form-factor pluggable (SFP) optics provides a simple and versatile solution for converting between two physical data formats. Use it to connect multimode to singlemode fiber, or singlemode fiber with different wavelengths. A wide range of interchangeable optics ensures the multi-rate line card will accommodate current and future system needs regardless of the network's data rate, protocol, or wavelength.

The multi-rate card supports a frequency range from 44.7 Mbps up to 2.7 Gbps, however, it is not a rate adapter that converts from one protocol to another. Only one data rate is configured manually through a set of DIP switches on the card, automatically through software auto-detection, or by changing the settings via software commands.

The card features loopback capability for testing link integrity, Link Loss Carry Forward and Link Loss Return for troubleshooting remote connections, and a clock and data recovery (CDR) circuit which can be bypassed for protocol transparency. The CDR circuitry extracts the clock and data information from the incoming stream and clears the signal from noise or jitter, which can significantly compromise the transmission of error-free data. The hot-swappable multi-rate line card is designed for use with the Radiance chassis system.

Compatible with the Coarse Wavelength Division Multiplexing (CWDM) System, the multi-rate line card supports Metrobility's CWDM pluggable optics with wavelengths from 1310 up to 1610 nm. When installed in a managed Radiance R5000 Central Service Platform, the multi-rate line card provides the interface between the service provider's switch and a wavelength-specific connection to the mux/demux module in an R4000 chassis. At the customer site, the multi-rate line card converts the specific wavelength back to a standard fiber media that matches the customer's equipment.

When configured with an R502-M management card, software management over the multi-rate line card allows a system administrator to monitor and configure the unit from a PC. Console commands, Metrobility's NetBeacon® or WebBeacon™ management software, or any standard SNMP application can be used for management. Through software, the multi-rate line card delivers real-time monitoring of its internal temperature, SFP optical receive/transmit power levels, and port link state, along with switch controls and other hardware data to simplify troubleshooting and to ensure system stability.

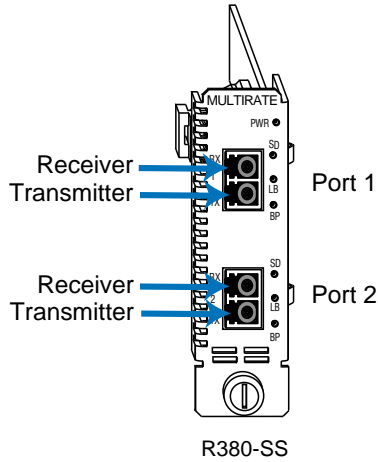

The Radiance multi-rate line card includes the following key features:

- Support for frequencies ranging from 44.7 Mbps up to 2.7 Gbps.
- Auto-detection or manual frequency settings.
- Temperature and optical power monitors.
- A wide range of SFP transceiver options compliant with Multi-Source Agreement (MSA) specifications.
- Full signal retiming, reshaping, and re-amplification (3 Rs) on both ports.
- Clock and data recovery (CDR) bypass capability for total protocol transparency.
- Independent loopback control on each port.
- Link Loss Carry Forward and Link Loss Return for troubleshooting remote network connections.
- In-band management of a remote unit via SNMP.
- Hot-swappable board and optics.

- Operates in any Metrobility chassis enclosure such as the Radiance R5000, R1000, R400, R200, or RD-20.
- Manageable using Metrobility's NetBeacon and WebBeacon element management software, or any standard SNMP-based management application.

Installation Guide

Follow the steps outlined in this section to install and start using the Radiance multi-rate line card.

NOTE: Electrostatic discharge precautions should be taken when handling any line card. Proper grounding is recommended (i.e., wear a wrist strap).

1 **Unpack the Line Card**

Your order has been provided with the safest possible packaging, but shipping damage does occasionally occur. Inspect your order carefully for damage that may have occurred during shipment. If you discover any shipping damage, notify your carrier and follow their instructions for damage and claims. Save the original shipping carton if return or storage of the unit is necessary.

2 **Set the DIP Switches**

Two sets of 6-position DIP switches are provided on the R380 line card. These switches, labeled SW1 and SW2, are used to enable/disable functions or to set the initial data rate. The default settings for the two banks of DIP switches are shown below.

Default DIP Switch Settings

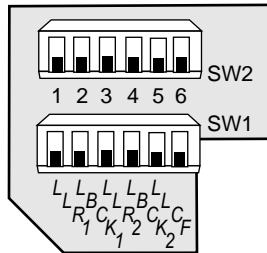

When setting DIP switches*, the UP position is when the lever of the switch is pushed away from the circuit board. The DOWN position is when the lever of the switch is pushed toward the circuit board.

* DIP switches can also be managed via console commands or through Metrobility NetBeacon or WebBeacon management software. Refer to the **Command Line Interface Reference Guide**, **NetBeacon Element Management Software Installation & User Guide** or **WebBeacon Management Software Installation & User Guide** for software management information.

Configuring the Data Rate

SW2 is used to set the initial data rate on the R380. The data rate is determined by the 6-bit binary code derived from the position of the DIP switches. The table below describes the settings supported by the multi-rate line card. 1=UP, 0=DOWN. The default setting is highlighted in yellow. To automatically detect the data rate, use the all 1s setting.

NOTE: The initial DIP switch setting may be overridden through software.

DIP Switch Position						Rate, Mbps	Protocol
1	2	3	4	5	6		
0	0	0	0	0	0	CDR bypass	Any protocol (DEFAULT)
1	0	0	0	0	0	44.7360	DS-3
0	1	0	0	0	0	51.8400	OC-1
1	1	0	0	0	0	125.0000	Fast Ethernet/FDDI
0	0	1	0	0	0	133.3125	FC-133
0	1	1	0	0	0	155.5200	OC-3/STM-1
0	0	0	1	0	0	200.0000	ESCON-200
1	0	0	1	0	0	266.6250	FC-266
0	0	1	1	0	0	531.2500	FC-531
0	1	1	1	0	0	622.0800	OC-12/STM-4
1	1	1	1	0	0	666.5143	OC-12/STM-4 (FEC)
0	0	0	0	1	0	1,000.0000	Reserved
1	0	0	0	1	0	1,062.5000	FC-1062
0	1	0	0	1	0	1,250.0000	Gigabit Ethernet
1	0	1	0	1	0	1,500.0000	Reserved
0	1	1	0	1	0	2,000.0000	Reserved
1	1	1	0	1	0	2,125.0000	FC-2125
0	0	0	1	1	0	2,250.0000	Reserved
1	0	0	1	1	0	2,375.0000	Reserved
0	1	0	1	1	0	2,488.3200	OC-48/STM-16
1	1	0	1	1	0	2,500.0000	Reserved
0	0	1	1	1	0	2,625.0000	Reserved
1	0	1	1	1	0	2,666.0570	OC-48/STM-16 (FEC)
1	1	1	1	1	1	Auto	Unknown protocol, auto-detect

Loopback (LBCK) Switch

Loopback is enabled independently on each port. When loopback is enabled, the port's transmitter is connected to its receiver, thus returning incoming data back to the sender. Use LBCK1 to set loopback on Port 1, and LBCK2 for Port 2. By default, LBCK is disabled (DOWN position) for normal data transmission from one port to the other.

Refer to [Loopback](#) in the User Guide section for further details.

Link Loss Carry Forward (LLCF) Switch

Link Loss Carry Forward is provided as an aid in troubleshooting remote connections. If the card loses link on one of its receivers, LLCF will inhibit the transmission of link pulses out the opposite port. LLCF applies to both ports.

For example, if LLCF is enabled and the multi-rate line card fails to detect link on Port 2, the card will not transmit link pulses from Port 1. In doing this, LLCF provides a way to extend the link loss indication beyond a single segment.

LLCF is enabled when the LLCF switch is in the UP position. The unit is shipped with LLCF disabled. For more information, refer to [Link Loss Carry Forward](#) in the User Guide section.

Link Loss Return (LLR) Switch

The multi-rate line card offers Link Loss Return functionality as an additional aid in troubleshooting remote connections. When LLR is enabled on a port, loss of link by the port's receiver stops its own transmitter from sending out link pulses. LLR is enabled independently on each port.

LLR1 enables/disables Link Loss Return on Port 1. LLR2 enables/disables the function on Port 2 of the multi-rate line card. To enable Link Loss Return, set the switch to the UP position. Set the switch DOWN to disable the LLR. The unit is shipped with LLR disabled.

For more information, refer to [Link Loss Return](#).

3 Install the SFP Optics

The R380 line card requires two small form-factor pluggable (SFP) optics. Optics are shipped separately. The table below lists the recommended optics to use based on the network protocol and fiber type.

Recommended SFP Optics

Protocol	Fiber Type			
	Multimode	Singlemode	BWDM	CWDM
DS-3	O280-M2	O283-20	O383-20-31 O383-20-55	O413-40-xx O413-80-xx
OC-1 / STM-0	O280-M2 O293-M5	O283-20	O383-20-31 O383-20-55	O413-40-xx O413-80-xx
Fast Ethernet / FDDI	O280-M2 O293-M5	O283-20 O293-20	O383-20-31 O383-20-55	O413-40-xx O413-80-xx
OC-3 / STM-1	O280-M2 O293-M5	O283-20 O293-20 O2A3-10	O383-20-31 O383-20-55	O413-40-xx O413-80-xx
ESCON	O293-M5	O293-20 O2A3-10		O413-40-xx O413-80-xx
OC-12 / STM-4	O293-M5	O293-20 O2A3-10		O411-80-47 to -61 O413-40-xx, O413-80-xx
Fibre Channel 1X	O211-M5	O2A3-10		O411-80-xx O413-40-xx, O413-80-xx
Gigabit Ethernet	O211-M5	O2A3-10	O311-10-31 O311-10-49	O411-80-xx O413-40-xx, O413-80-xx
Fibre Channel 2X	O211-M5	O2A3-10		O413-40-xx O413-80-xx
OC-48 / STM-16		O2A3-10		O413-40-xx O413-80-xx

To install the optics, align the SFP module so the receiver (▲) is positioned above the transmitter (▼). For a BWDM module, align it so the visible part of the circuit board located at the back of the module is to the right. Slide the module into the empty slot. Push the SFP firmly in place. Remove the protective covering on the connector.

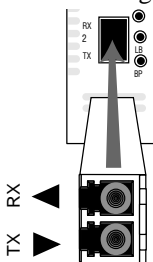

IMPORTANT: The multi-rate line card is designed and tested to operate using only Metrobility-supplied SFP transceivers. Safety, performance, and reliability are guaranteed only when Metrobility-supplied transceivers are used. **Installing unspecified parts may damage the product and will void the unit's warranty.**

4

Install the Line Card

The Radiance R380 offers the ease of plug-and-play installation and is hot-swappable. The card must be secured firmly to the chassis before making network connections. Follow the simple steps outlined below to install the multi-rate line card.

- Grasp the card by the front panel as shown.

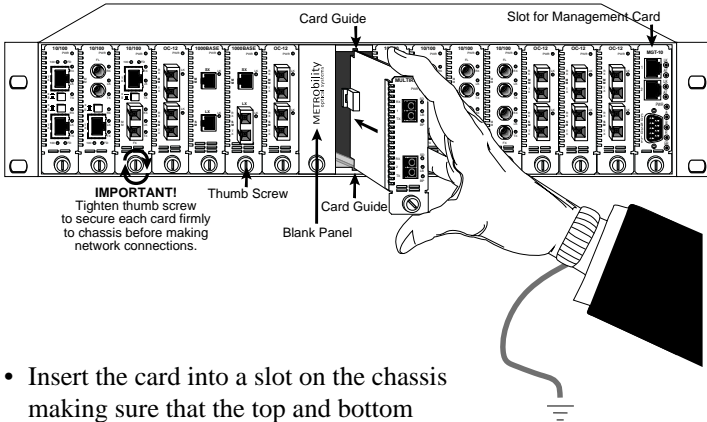

- Insert the card into a slot on the chassis making sure that the top and bottom edges of the circuit board are aligned with the top and bottom card guides in the chassis. Do not force the card into the chassis unnecessarily. It should slide in easily and evenly.
- Slide the card in until the top and bottom edges of the front panel are flush and even with the top and bottom edges of the chassis.
- Turn the thumbscrew clockwise until it is snug to secure the card to the chassis. The card is now properly installed and ready for connection to the network.

5

Connect to the Network

To connect the line card to the network, insert the fiber cables into the appropriate connectors as illustrated below. Make sure the card is secured to the chassis before making network connections. Once power is applied to the unit, correct connectivity can be verified via the signal detect (SD) LED, which should be lit.

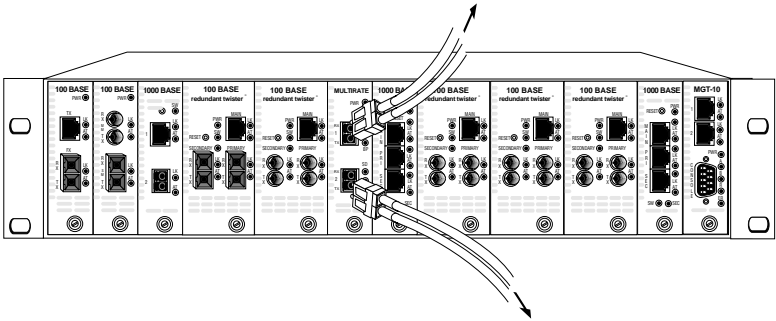

The R380-SS multi-rate line card provides two fiber optic ports. Each port supports a set of LC or SC connectors with the receiver (RX) located above the transmitter (TX). For maximum versatility in designing or expanding your network, the ports support any combination of the following Metrobility-supplied SFP transceivers. The maximum distance supported by each model is listed below:

Model #	Fiber Type	Max Distance
O211-M5	multimode	500 m
O280-M2	multimode	2 km
O283-20	singlemode	20 km
O293-20	singlemode	20 km
O293-M5	multimode	500 m
O2A3-10	singlemode	10 km
O311-10-xx	singlemode	10 km
O383-20-xx	singlemode	20 km
O411-80-xx	singlemode	80 km
O413-40-xx	singlemode	40 km
O413-80-xx	singlemode	80 km

For more information about optics, refer to [Technical Specifications](#).

IMPORTANT: *The distances noted are for reference purposes only. The most important factor to achieve the desired distance is the optical power budget. Metrobility specifications indicate the typical transmit power budget. The actual distance is a function of the fiber type and quality, the number and quality of splices, the type and quality of connectors, the transmission loss, and other physical characteristics.*

When making fiber optic connections, make sure that the optical transmitter (TX) on the Radiance multi-rate line card connects to the optical receiver on the connected device, and that the optical transmitter on the device connects to the optical receiver (RX) on the Radiance card.

Use the SD LEDs on the front panel of the card to verify correct segment connectivity. As you insert the cable into each port, the SD LED will be lit if the following conditions are met:

- Power is being applied to the chassis.
- All connections are secure and the cables are undamaged.
- There is an active device connected to the other end of the cable, and it is sending idle signals.
- The port's receiver detects the presence of optical power and the port's CDR circuitry has locked onto the incoming signal.

For information on replacing the SFP transceiver, refer to [Changing the SFP Optics](#).

BWDM Interface

The bidirectional wavelength division multiplexed (BWDM) transceiver provides one singlemode SC connector. The O311-10-xx supports a maximum segment length of 10 km; the O383-20-xx supports a maximum segment length of 20 km. BWDM transceivers must always be used in complementary pairs. That is, the O311-10-31 must be connected to the O311-10-49, and the O383-20-31 must be connected to the O383-20-55.

The O311-10-31 transmits data at a wavelength of 1310 nm and receives at 1490 nm. Correspondingly, the O311-10-49 transmits at 1490 nm and receives at 1310 nm. The O383-20-31 transmits at 1310 nm and receives at 1550 nm; the O383-20-55 transmits at 1550 nm and receives at 1310 nm.

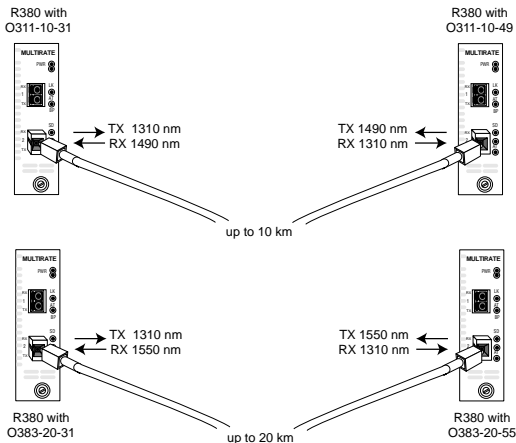

User Guide

This section contains information regarding the operating features of the Radiance multi-rate line card.

LED Operation

Several LEDs are visible on the front panel. These include the power (PWR), signal detect (SD), loopback (LB), and bypass (BP) LEDs. There are separate signal detect, loopback, and bypass LEDs for each port. Refer to the table below for a description of each LED.

The function of each LED is as follows:

LED Label	LED Name	Color / Status	Indication
PWR	Power	Green	Power is being supplied to the unit.
		OFF	Unit is not receiving power.
SD	Signal Detect / Lock Detect	Green	Port detects an optical signal and is locked onto it.
		Yellow	Port detects an optical signal, but cannot lock onto it.
		OFF	Port does not detect any optical signal, or there is no SFP installed.
LB	Loopback	Green	Port is in loopback mode. Port's transmitter is connected to its own receiver.
		OFF	Normal operation. Port's transmitter is connected to other port's receiver.
BP	CDR Bypass	Green	Port's CDR circuitry is being bypassed.
		OFF	Port's CDR is active.

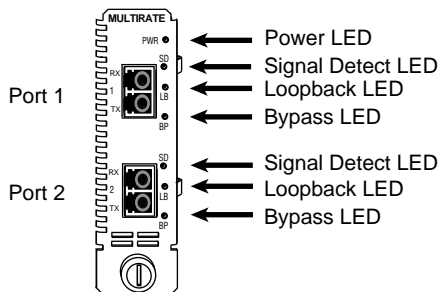

SFP Monitors

Advanced management capabilities on the Radiance multi-rate line card enables the monitoring of the following parameters for each SFP port transceiver with digital diagnostics.

- Optical transmit power in dBm
- Optical receive power in dBm
- SFP transceiver's internal temperature (range is -40° to +125° C)

These monitors can assist in ensuring optimal performance and system stability. The SFP optics also provide useful information about the port interface.

- Connector type (e.g., LC or SC)
- Wavelength in nanometers
- Link length in meters supported by the SFP transceiver

* Refer to the *Command Line Interface Reference Guide, NetBeacon Element Management Software Installation & User Guide* or *WebBeacon Management Software Installation & User Guide* for software management information.

Loopback

The Radiance multi-rate line card features loopback testing capability to help verify proper operation and to isolate problems within a particular segment of the network. During loopback, the LBK LED is yellow. Loopback is enabled/disabled in two ways: (1) setting the LBCK DIP switch(es), or (2) through software by enabling loopback on Port 1 and/or 2. Once loopback is enabled, the card remains in this mode until you reset the DIP switch or change the software setting.

Normal Operation

During normal operation (loopback disabled), data from a local device enters the local multi-rate line card through Port 1, passes through the fiber line between the two cards, exits through Port 1 on the remote multi-rate line card, then enters the remote device. The path is reversed for incoming data to the local device.

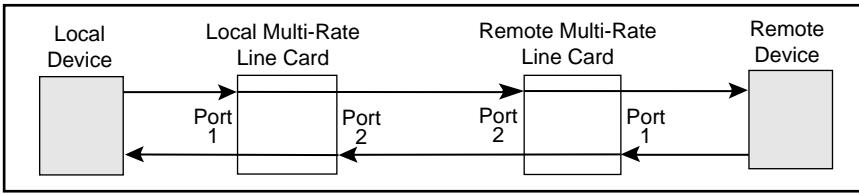

Local Port Loopback

Loopback can be applied individually to either port on a multi-rate line card. The following diagrams illustrate the flow of data when loopback is enabled independently on Port 1 and on Port 2.

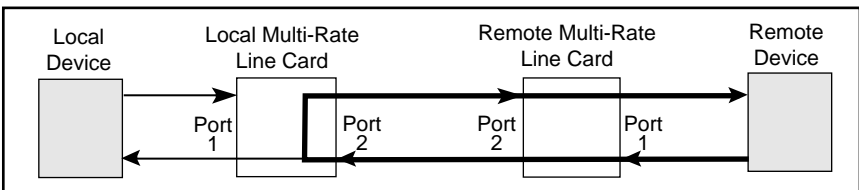
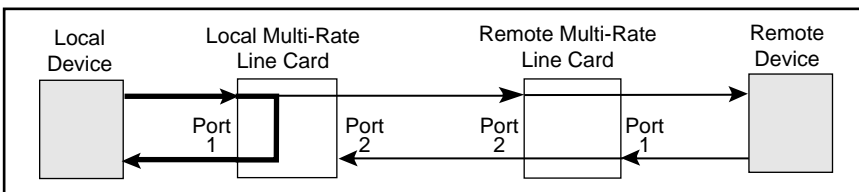

Dual-Port Loopback

In this mode, data on both ports of the multi-rate line card are looped back to their sending devices. Dual-port loopback is configurable through hardware or software by enabling loopback on Port 1 and Port 2 simultaneously.

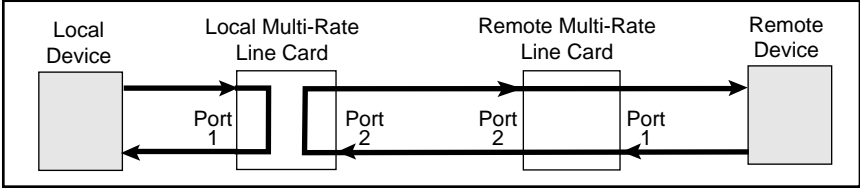

Link Loss Return

Both ports on the Radiance multi-rate interface line card are designed with Link Loss Return functionality for troubleshooting remote connections. When LLR is enabled*, the port's transmitter shuts down if its receiver fails to detect a valid link signal. LLR should only be enabled on one end of a cable and is typically enabled on either the unmanaged or remote device. LLR works in conjunction with LLCF.

The diagram below shows a typical network configuration with good link status using two Radiance multi-rate line cards for remote connectivity. Note that LLR and LLCF are enabled as indicated in the diagram.

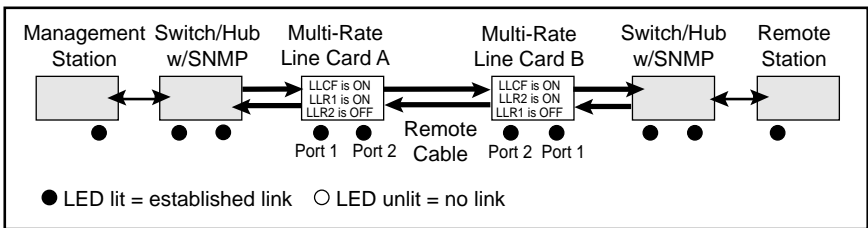

Example: If one of the optical conductors breaks (as shown in the diagram box below), Multi-Rate Line Card B, with LLR2 enabled, will return a no-link condition to its link partner, Port 2 on Line Card A. Using two R380-SS cards with LLCF enabled on both cards, the no-link condition is carried forward to the switch/hub where a trap is generated to the management station. The network administrator can then determine the source of the loss.

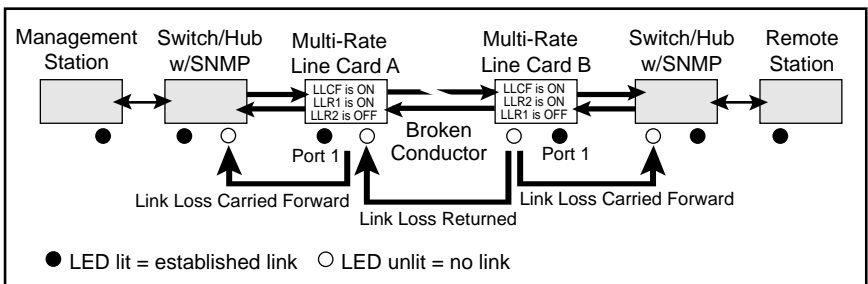

IMPORTANT: Do NOT enable LLR on both ends of the same cable. If LLR is enabled on both ends, the link will never be established.

*Units are shipped with the LLR disabled (DOWN).

Link Loss Carry Forward

The Radiance multi-rate line card incorporates LLCF to assist in troubleshooting a remote connection. When LLCF is enabled*, the ports do not transmit a signal until they receive a signal from the opposite port. When a lost link signal is returned to an unmanaged line card, that lost link must then be carried forward to a managed device (switch/hub) for trap generation.

The diagram below shows a typical network configuration with good link status using two Radiance multi-rate line cards for remote connectivity. Note that LLCF is enabled as indicated in the diagram.

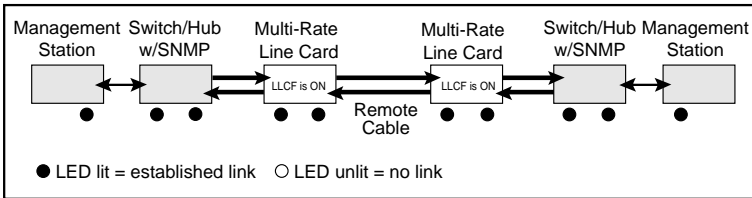

If a connection breaks, the line cards will carry that link loss forward to a switch/hub which generates a trap to the management station. The network administrator can then determine the source of the problem.

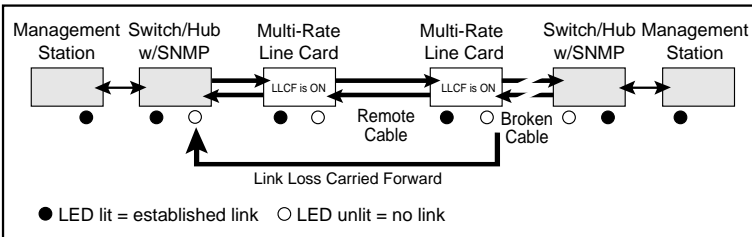
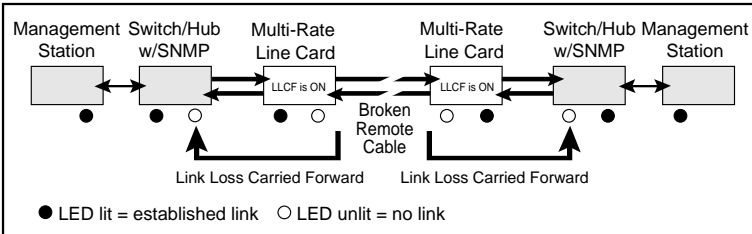

NOTE: Loopback takes precedence over LLCF. If LLCF and loopback are both enabled, LLCF functionality will be ignored for the port that is in loopback. LLCF will remain in effect for the port that is not in loopback.

*Units are shipped with the LLCF disabled (DOWN).

Topology Solutions

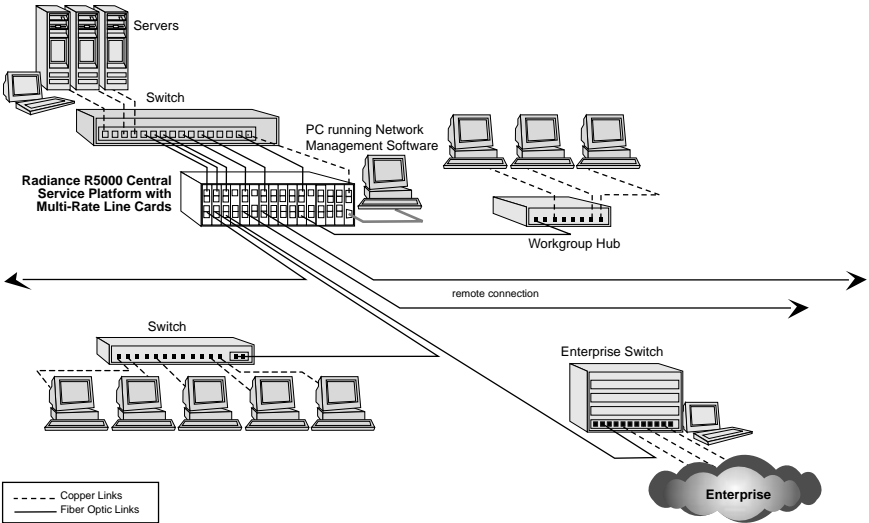

Coarse Wavelength Division Multiplexing (CWDM)

Using the CWDM optics, the multi-rate line cards can be integrated into a Radiance CWDM system, in which a single fiber pair carries data bidirectionally on multiple wavelengths. In the following examples, each colored line represents a different wavelength. The network connections are shown in gray with the magnification circles displaying the wavelengths carried on the lines. Connections to the end user are shown in dark gray.

POINT TO POINT TOPOLOGY

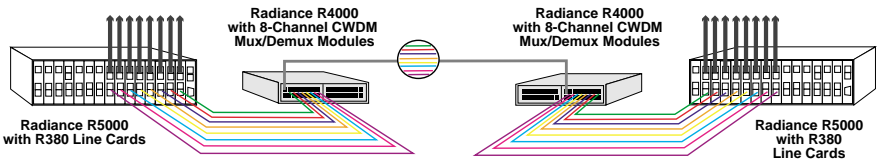

RING TOPOLOGY

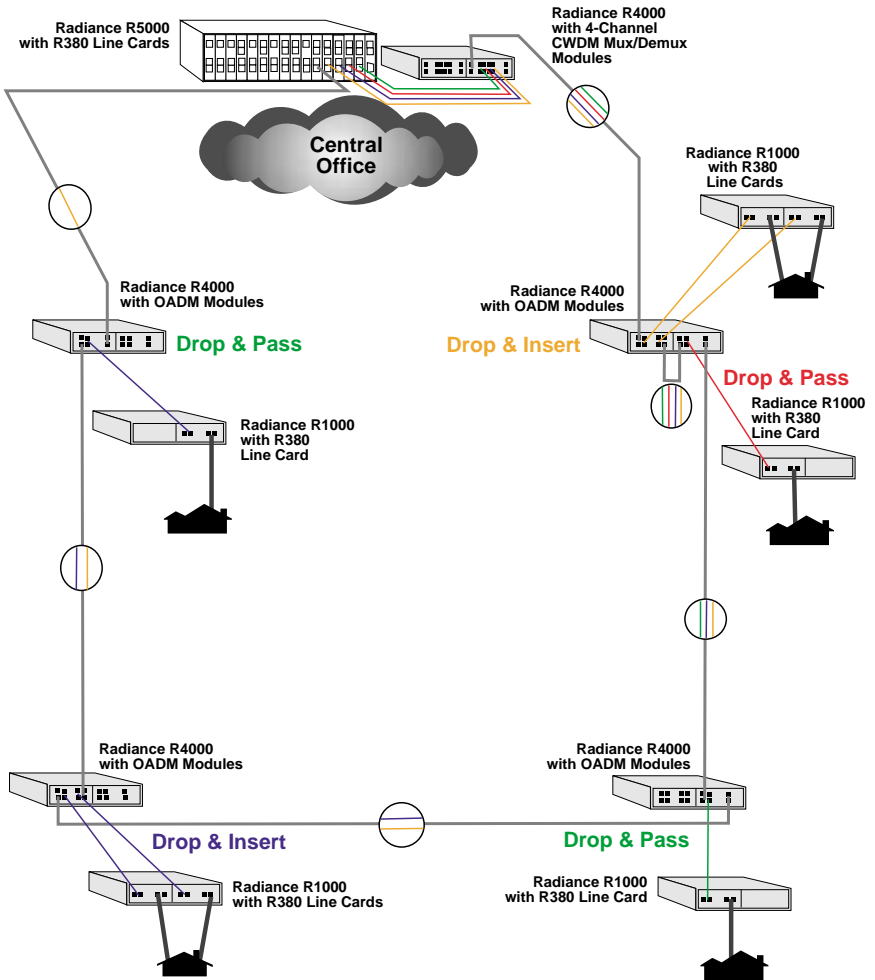

Changing the SFP Optics

The multi-rate line card supports two replaceable small form-factor pluggable (SFP) transceivers. This section explains how to remove and install the optics on the card. Metrobility SFP transceivers are hot-swappable.

IMPORTANT: Use only Metrobility SFP transceivers with this product. Installing any other optics may damage the unit and will void the product's warranty.

1. Disconnect the fiber optic network cables, if they are installed, from both the receiver (RX) and transmitter (TX) of the SFP transceiver.

WARNING: Avoid looking into the laser from the connector or fiber cable.

2. To remove the SFP optics from the multi-rate line card, simply pull the release mechanism (i.e., plastic tab, release wire, etc.) and slide the module out of the slot.

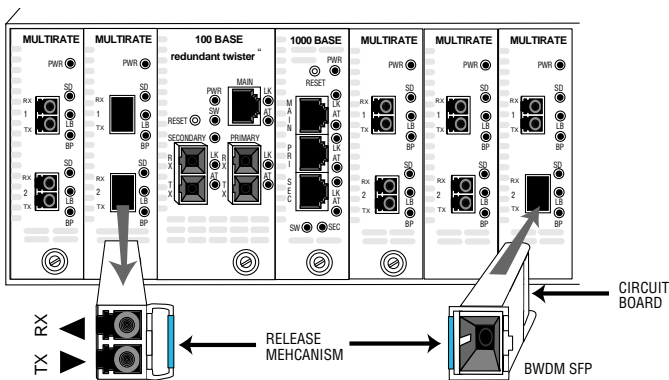

3. Align the new SFP module so the receiver (▲) is positioned above the transmitter (▼). For a BWDMM SFP, align it so the visible part of the circuit board located at the back of the module is to the right.
4. Slide the new SFP module into the slot, pushing it firmly in place.
5. Remove the protective dust cover on the LC connector.
6. Reconnect the network cables. Verify proper segment connectivity via the green LK LED, which will be lit.

Technical Specifications

Data Rate _____ 44.7 Mbps to 2.7 Gbps, depending on optics

Power Requirements _____ 5 V DC @ 1 A, 5 W

Environmental

Operating Temperature _____ 0 to 50° C

Storage Temperature _____ -30 to 70° C

Operating Humidity _____ 5% to 95% non-condensing

Weight _____ 5 oz (0.14 kg)

Multimode Fiber Optic Plug-in (O211-M5)

Connector _____ LC

Wavelength _____ 850 nm

Data Rate _____ 1062.5 Mbps to 2125 Mbps

RX Input Sensitivity ____ -19 dBm (min); -22 dBm (typical); 0 dBm (saturation)

Output Power _____ -9 dBm to -3.5 dBm; 6 dBm (typical)

Typical Link Budget _____ 16 dB

Supported Link Length _____ up to 500 m

Cable Type _____ 50/125 or 62.5/125 µm multimode

Multimode Fiber Optic Plug-in (O280-M2)

Connector _____ LC

Wavelength _____ 1310 nm

Data Rate _____ 45 Mbps to 155 Mbps

RX Input Sensitivity ____ -32 dBm (min); -34 dBm (typical); -14 dBm (saturation)

Output Power _____ -19 dBm to -14 dBm; -17 dBm (typical)

Typical Link Budget _____ 17 dB

Supported Link Length _____ up to 2 km

Cable Type _____ 50/125 or 62.5/125 µm multimode

Multimode Fiber Optic Plug-in (O293-M5)

Connector _____ LC

Wavelength _____ 1300 nm

Data Rate _____ 50 Mbps to 500 Mbps

RX Input Sensitivity ____ -26 dBm (min); -28 dBm (typical); -12 dBm (saturation)

Output Power _____ -20 dBm to -14 dBm; -18 dBm (typical)

Typical Link Budget _____ 10 dB

Supported Link Length _____ up to 500 m @ 622 Mbps; 2 km @ 156 Mbps

Cable Type _____ 50/125 or 62.5/125 µm multimode

Singlemode Fiber Optic Plug-in (O311-10-49) for BWDM

Connector _____ SC
TX Wavelength _____ 1490 nm
RX Wavelength _____ 1310 nm
Data Rate _____ 1250 Mbps
RX Input Sensitivity ____ -22 dBm (min); -24 dBm (typical); -3 dBm (saturation)
Output Power _____ -9 dBm to -3 dBm; -6 dBm (typical)
Typical Link Budget _____ 18 dB
Supported Link Length _____ up to 10 km
Cable Type _____ 9/125 μ m singlemode

Singlemode Fiber Optic Plug-in (O311-10-31) for BWDM

Connector _____ SC
TX Wavelength _____ 1310 nm
RX Wavelength _____ 1490 nm
Data Rate _____ 1250 Mbps
RX Input Sensitivity ____ -22 dBm (min); -24 dBm (typical); -3 dBm (saturation)
Output Power _____ -9 dBm to -3 dBm; -6 dBm (typical)
Typical Link Budget _____ 18 dB
Supported Link Length _____ up to 10 km
Cable Type _____ 9/125 μ m singlemode

Singlemode Fiber Optic Plug-in (O383-20-31) for BWDM

Connector _____ SC
TX Wavelength _____ 1310 nm
RX Wavelength _____ 1550 nm
Data Rate _____ 10 Mbps to 155 Mbps
RX Input Sensitivity ____ -28 dBm (min); -30 dBm (typical); -8 dBm (saturation)
Output Power _____ -14 dBm to -8 dBm; -11 dBm (typical)
Typical Link Budget _____ 19 dB
Supported Link Length _____ up to 20 km
Cable Type _____ 9/125 μ m singlemode

Singlemode Fiber Optic Plug-in (O383-20-55) for BWDM

Connector _____ SC
TX Wavelength _____ 1550 nm
RX Wavelength _____ 1310 nm
Data Rate _____ 10 Mbps to 155 Mbps
RX Input Sensitivity ____ -28 dBm (min); -30 dBm (typical); -8 dBm (saturation)
Output Power _____ -14 dBm to -8 dBm; -11 dBm (typical)
Typical Link Budget _____ 19 dB
Supported Link Length _____ up to 20 km
Cable Type _____ 9/125 μ m singlemode

Singlemode Fiber Optic Plug-in (O283-20)

Connector _____ LC
Wavelength _____ 1310 nm
Data Rate _____ 10 Mbps to 155 Mbps
RX Input Sensitivity ____ -28 dBm (min); -32 dBm (typical); -8 dBm (saturation)
Output Power _____ -15 dBm to -8 dBm; -11.5 dBm (typical)
Typical Link Budget _____ 20.5 dB
Supported Link Length _____ up to 20 km
Cable Type _____ 9/125 μ m singlemode

Singlemode Fiber Optic Plug-in (O293-20)

Connector _____ LC
Wavelength _____ 1310 nm
Data Rate _____ 125 Mbps to 622 Mbps
RX Input Sensitivity _ -28 dBm (min); -30.5 dBm (typical); -8 dBm (saturation)
Output Power _____ -15 dBm to -8 dBm; -11.5 dBm (typical)
Typical Link Budget _____ 19 dB
Supported Link Length _____ up to 20 km
Cable Type _____ 9/125 μ m singlemode

Singlemode Fiber Optic Plug-in (O2A3-10)

Connector _____ LC
Wavelength _____ 1310 nm
Data Rate _____ 155 Mbps to 2670 Mbps
RX Input Sensitivity ____ -20 dBm (min); -22 dBm (typical); 0 dBm (saturation)
Output Power _____ -10 dBm to -3 dBm; -6 dBm (typical)
Typical Link Budget _____ 16 dB
Supported Link Length _____ up to 10 km
Cable Type _____ 9/125 μ m singlemode

Singlemode Fiber Optic Plug-in (O411-80-31 to -45) for CWDM

Connector _____ LC
Wavelength _____ (see tables on next page)
Data Rate _____ 1.062 Gbps to 1.25 Gbps
RX Input Sensitivity ____ -24 dBm (min); -26 dBm (typical); 0 dBm (saturation)
Output Power _____ 0 dBm to 5 dBm; 2 dBm (typical)
Typical Link Budget _____ 28 dB
Supported Link Length _____ up to 80 km
Cable Type _____ 9/125 μ m singlemode

Singlemode Fiber Optic Plug-in (O411-80-47 to -61) for CWDM

Connector _____ LC
 Wavelength _____ (see tables on next page)
 Data Rate _____ 622 Mbps to 1.25 Gbps
 RX Input Sensitivity ____ -23 dBm (min); -25 dBm (typical); 0 dBm (saturation)
 Output Power _____ 0 dBm to 5 dBm; 2 dBm (typical)
 Typical Link Budget _____ 27 dB
 Supported Link Length _____ up to 80 km
 Cable Type _____ 9/125 μm singlemode

Singlemode Fiber Optic Plug-in (O413-40-xx) for CWDM

Connector _____ LC
 Wavelength _____ (see tables below)
 Data Rate _____ 45 Mbps to 2.7 Gbps
 RX Input Sensitivity ____ -20 dBm (min); -22 dBm (typical); 0 dBm (saturation)
 Output Power _____ 0 dBm to +4 dBm; +1.5 dBm (typical)
 Typical Link Budget _____ 23.5 dB
 Supported Link Length _____ up to 40 km
 Cable Type _____ 9/125 μm singlemode

Singlemode Fiber Optic Plug-in (O413-80-xx) for CWDM

Connector _____ LC
 Wavelength _____ (see tables below)
 Data Rate _____ 45 Mbps to 2.7 Gbps
 RX Input Sensitivity ____ -30 dBm (min); -32 dBm (typical); -8 dBm (saturation)
 Output Power _____ 0 dBm to +4 dBm; +1.5 dBm (typical)
 Typical Link Budget _____ 33.5 dB
 Supported Link Length _____ up to 80 km
 Cable Type _____ 9/125 μm singlemode

CWDM Optics Wavelengths

Model Number	Wavelength	Model Numbers	Wavelength
O411-80-31	1310 nm	O411-80-47, O413-40-47, O413-80-47	1470 nm
O411-80-33	1330 nm	O411-80-49, O413-40-49, O413-80-49	1490 nm
O411-80-35	1350 nm	O411-80-51, O413-40-51, O413-80-51	1510 nm
O411-80-37	1370 nm	O411-80-53, O413-40-53, O413-80-53	1530 nm
O411-80-39	1390 nm	O411-80-55, O413-40-55, O413-80-55	1550 nm
O411-80-41	1410 nm	O411-80-57, O413-40-57, O413-80-57	1570 nm
O411-80-43	1430 nm	O411-80-59, O413-40-59, O413-80-59	1590 nm
O411-80-45	1450 nm	O411-80-61, O413-40-61, O413-80-61	1610 nm

Acronyms and Abbreviations

BP	Bypass
BWDM	Bidirectional Wavelength Division Multiplexing
CDR	Clock and Data Recovery
CDRB	Clock and Data Recovery Bypass
CWDM	Coarse Wavelength Division Multiplexing
dB	Decibel
dBm	Decibels relative to 1 mW of power (0 dBm equals 1 mW)
DS	Digital Signal
ESCON	Enterprise Systems Connection
FC	Fibre Channel
FEC	Forward Error Correction
FDDI	Fiber-Distributed Data Interface
Gbps	Gigabits per second
GigE	Gigabit Ethernet
km	Kilometer
LB	Loopback
LBCK	Loopback
LED	Light emitting diode
LLCF	Link Loss Carry Forward
LLR	Link Loss Return
Mbps	Megabits per second
MSA	Multi-Source Agreement
nm	Nanometer
OC	Optical Carrier
PWR	Power
RX	Receive
SD	Signal Detect
SFP	Small Form-Factor Pluggable
TDM	Time-Division Multiplexing
TX	Transmit

Product Safety, EMC and Compliance Statements

This equipment complies with the following requirements:

- UL
- CB
- CSA
- EN60950 (safety)
- FCC Part 15, Class A
- EN55022 Class A (emissions)
- ICES-003 Class A (emissions)
- EN55024: 1998 (immunity)
- IEC 825-1 Classification
- Class 1 Laser Product
- NEBS Level III

This product shall be handled, stored and disposed of in accordance with all governing and applicable safety and environmental regulatory agency requirements.

The following *FCC* and *Industry Canada* compliance information is applicable to North American customers only.

USA FCC Radio Frequency Interference Statement

This equipment has been tested and found to comply with the limits for a Class A digital device, pursuant to Part 15 of the FCC Rules. These limits are designed to provide reasonable protection against harmful interference when the equipment is operated in a commercial environment. This equipment generates, uses and can radiate radio frequency energy, and if not installed and used in accordance with the instruction manual, may cause harmful interference to radio communications. Operation of this equipment in a residential area is likely to cause harmful interference in which case the user will be required to correct the interference at his own expense.

***Caution:** Changes or modifications to this equipment not expressly approved by the party responsible for compliance could void the user's authority to operate the equipment.*

Canadian Radio Frequency Interference Statement

This Class A digital apparatus meets all requirements of the Canadian Interference-Causing Equipment Regulations.

Cet appareil numérique de la classe A respecte toutes les exigences du Règlement sur le matériel brouilleur du Canada.

Warranty and Servicing

Three-Year Warranty for the Radiance Multi-Rate Line Card

Metrobility Optical Systems, Inc. warrants that every Radiance multi-rate line card will be free from defects in material and workmanship for a period of THREE YEARS from the date of Metrobility shipment. This warranty covers the original user only and is not transferable. Should the unit fail at any time during this warranty period, Metrobility will, at its sole discretion, replace, repair, or refund the purchase price of the product. This warranty is limited to defects in workmanship and materials and does not cover damage from accident, acts of God, neglect, contamination, misuse or abnormal conditions of operation or handling, including overvoltage failures caused by use outside of the product's specified rating, or normal wear and tear of mechanical components.

To establish original ownership and provide date of purchase, complete and return the registration card or register the product online at www.metrobility.com. If product was not purchased directly from Metrobility, please provide source, invoice number and date of purchase.

To return a defective product for warranty coverage, contact Metrobility Customer Service for a return materials authorization (RMA) number. Send the defective product postage and insurance prepaid to the address provided to you by the Metrobility Technical Support Representative. Failure to properly protect the product during shipping may void this warranty. The Metrobility RMA number must be clearly on the outside of the carton to ensure its acceptance.

Metrobility will pay return transportation for product repaired or replaced in-warranty. Before making any repair not covered by the warranty, Metrobility will estimate cost and obtain authorization, then invoice for repair and return transportation. Metrobility reserves the right to charge for all testing and shipping costs incurred, if test results determine that the unit is without defect.

This warranty constitutes the buyer's sole remedy. No other warranties, such as fitness for a particular purpose, are expressed or implied. Under no circumstances will Metrobility be liable for any damages incurred by the use of this product including, but not limited to, lost profits, lost savings, and incidental or consequential damages arising from the use of, or inability to use, this product. Authorized resellers are not authorized to extend any other warranty on Metrobility's behalf.

ADDITIONAL IMPORTANT WARRANTY INFORMATION:

The Radiance multi-rate line card is designed to operate using only the Metrobility-supplied small form-factor pluggable (SFP) transceivers specified in this manual. The use and installation of parts not included in this document will void the product's warranty and may cause damage to the unit.

Product Manuals

The most recent version of this manual is available online at

<http://www.metrobility.com/support/manuals.htm>

Product Registration

To register your product, go to

<http://www.metrobility.com/support/registration.asp>

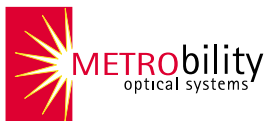

25 Manchester Street, Merrimack, NH 03054 USA

tel: 1.603.880.1833 • fax: 1.603.594.2887

www.metrobility.com